



# **HVX-Series Diesel Engine Shut Down Valves**

**(Oil Pressure Latched Types with Manual Start Override/Emergency Stop)**

**Selection, Application and Maintenance**

Valve Numbers HVX-300 HVX-500
----------------------------------

# Diesel Engine Shutdown Valves - HVX 300 - 500

## DESCRIPTION

Based on the Chalwyn 3" and 5" slimfit butterfly types these air intake shut down valves are designed to be latched open by engine oil pressure. Manual start override is via a cable from a remote lever assembly (RLX-100). Once the engine is running the valve is held in the run position by lubricating oil pressure. Valve closure will occur if the oil pressure drops below about 20psi (1.4bar). Emergency manual stop is by returning the lever RLX-100 to the stop position.

HVX-300 and HVX-500 valves are suitable for both hazardous and non-hazardous area applications. They are available in basic flange mounted form or fitted with hose adaptors and/or flametrap housing. Valve body and disc are manufactured in corrosion resistant hard anodised aluminium. The valve spindle is in 316 stainless steel.

## Typical HVX Valve Arrangement

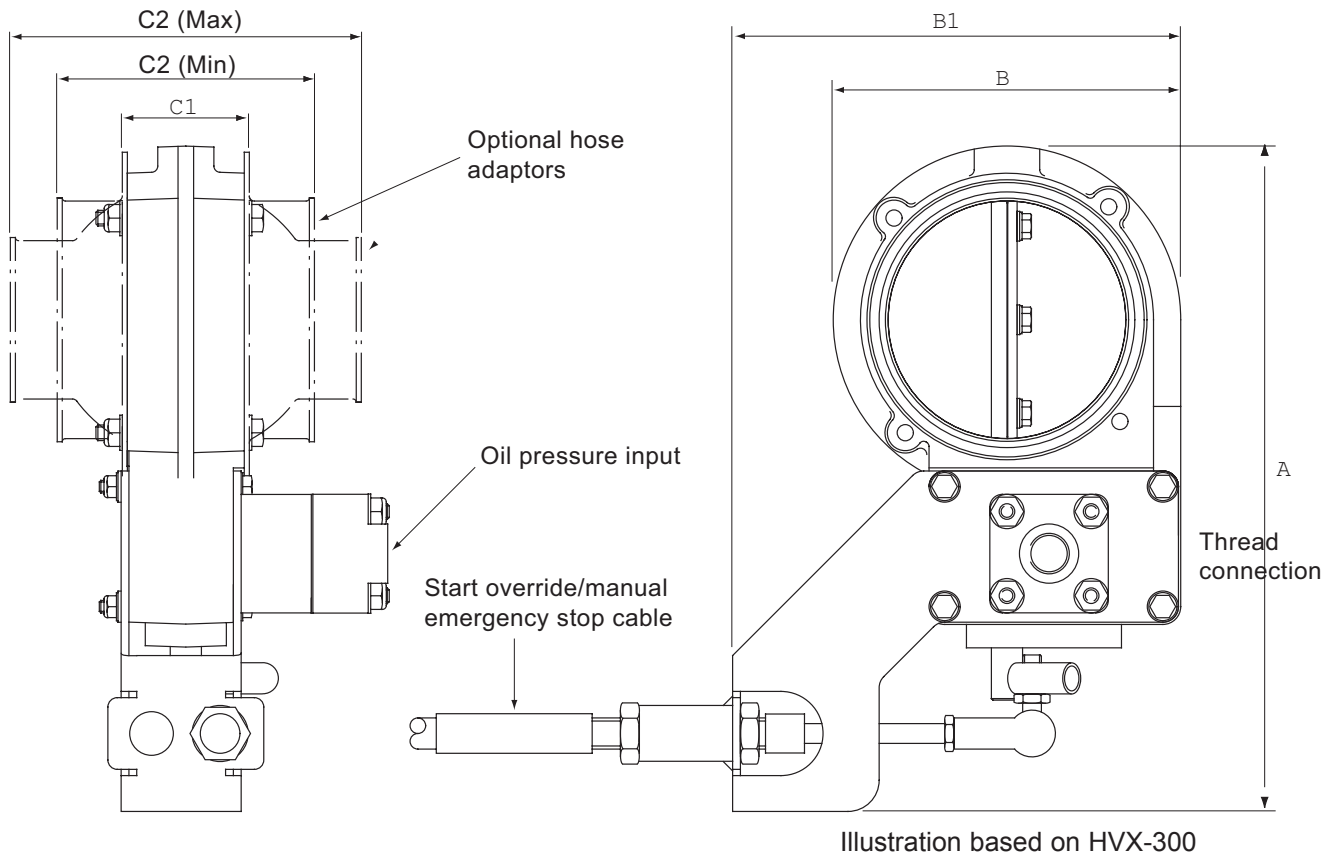

## Main Dimensions (mm)

Valve Type	Nominal Bore Diameter	A mm	B mm	B1 mm	C1 mm	C2 minimum & maximum
HVX-300	76 (3")	213.5	111.5	144	37.5	82.5 to 112.5
HVX-500	127 (5")	270	167	171.5	45.5	102.0 to 157.5

### Note:

Maximum temperature of the engine intake air at the HVX valve not to exceed 150°C. (See also "Installation" - Page 4).

# Diesel Engine Shutdown Valves - HVX 300 - 500

## SELECTION

Determine the size and position of the HVX valve to be installed. Within the various constraints imposed in the application the valve should be as generously sized as possible. The length of the start override/manual stop cable needs to be determined. The start override lever (RLX-100) should be positioned where both convenient for operating and also from where a direct cable run to the valve with a minimum of tight bends if possible.

The HVX range of valves are designed for flange mounting but can also be supplied fitted with hose adaptors selected from the table below.

## Hose Adaptor Options

76mm (3") Bore Valves	
Adaptor Part Number	To Suit Hose Bore mm (inches)
HAX-320	38 (1½)
HAX-322	44.5 (1¾)
HAX-301	51 (2)
HAX-303	57 (2¼)
HAX-304	60 (2⅜)
HAX-305	63.5 (2½)
HAX-306	67 (2⅝)
HAX-307	70 (2¾)
HAX-309	76 (3)
HAX-312	82.5 (3¼)
HAX-314	89 (3½)
HAX-319	102 (4)

127mm (5") Bore Valves	
Adaptor Part Number	To Suit Hose Bore mm (inches)
HAX-501	89 (3½)
HAX-503	95 (3¾)
HAX-505	102 (4)
HAX-507	108 (4¼)
HAX-509	114 (4½)
HAX-511	121 (4¾)
HAX-513	127 (5)
HAX-518	140 (5½)
HAX-523	152 (6)

## Override Cable Options (other lengths may be available on request)

Cable Identity	Cable Length
CHW-100	1.0m
CHW-200	2.0m
CHW-250	2.5m
CHW-300	3.0m

# Diesel Engine Shutdown Valves - HVX 300 - 500

---

## INSTALLATION

1. In the case of a naturally aspirated engine, the Chalwyn HVX shut down valve should generally be fitted as close to the engine air intake manifold as possible. If an intake flame trap is also fitted, the HVX valve must be installed upstream (air cleaner side) of the flame trap.
2. To avoid excessively high intake air temperatures at the HVX valve when fitted to a turbocharged engine, it may be necessary to fit the valve either upstream of the turbocharger or downstream of the intercooler (if fitted). Again, if an air intake flametrap is also fitted, the valve must be installed upstream of the flametrap.
3. HVX intake shut down valves may be installed either horizontally or vertically.
4. If hose adaptors are used, the mating hose should be of a re-inforced type, provide adequate support for the valve and prevent excessive vibration. If necessary, additional support brackets mounted from the engine should be considered.
5. Particular care must be taken to ensure the integrity of the intake pipework between the Chalwyn valve and intake manifold. Ideally metal pipework should be used and any gaps kept as short as possible, (taking into account any relative movement) and closed by reinforced hose. The possibility of a hose collapse on closure of the shut down valve should be avoided.
6. Any engine crankcase breather connections into the intake system between the HVX valve and engine, or any internal crankcase breather arrangement venting directly into the engine intake ports must be sealed and replaced by an external breather system venting either to atmosphere or to the intake system upstream of the shut down valve. External breather system kits for various engine types are available from Chalwyn.
7. The lever assembly RLX-100 should be mounted using the three through holes provided in the assembly. It must be positioned where convenient for operation but also such that a reasonably straight run without tight bends if possible for the override cable run between the lever assembly and valve.
8. The lever RLX-100 is sprung towards the valve closed position. With no oil pressure applied the HVX valve is also sprung to the closed position. With both the RLX-100 and HVX valve in the closed position fit the override cable. Adjust cable and tighten the locknuts such that with the HVX valve fully closed, the end of the lever RLX-100 is positioned about 5 to 10mm from its central stop (closed) position. When the RLX-100 is exercised over its operating stroke the distinct sound of the HVX valve closing should now be audible.

# Diesel Engine Shutdown Valves - HVX 300 - 500

---

## OPERATION

1. Prior to starting engine use the start override lever to open the HVX valve to the run position.
2. Continue to hold the valve in the run position whilst starting and running up engine.
3. Once engine has run up, the engine oil pressure will latch the HVX valve in the run position. The override lever may then be released and should remain in the run position.
4. Should engine oil pressure at the HVX valve fall below about 20psi (1.4bar) the HVX will close and stop the engine.
5. To carry out a manual emergency stop, move the start override lever from the run position back to the stop (valve closed) position.

## MAINTENANCE

---

### MONTHLY:

Check that the fasteners locating the HVX valve and any associated intake system or support bracket fasteners are tight.

Check that any flexible hoses in the air intake system between the HVX valve and engine are free from damage and suitable for further service.

Check that the oil pressure pipe to the HVX valve is properly supported, free from damage and that the pipe fittings are tight and leak free.

Start engine. Run at or just above low idle speed. Carry out a manual emergency stop. The engine should stop within a few seconds of moving the start override lever from the run to stop position.

If not:

- a) Check then engine air intake system for freedom from leaks.
- b) Check that the start override cable is properly adjusted.

Should these checks not resolve the problem return the HVX valve to Chalwyn for inspection.



### **Americas**

---

AMOT - USA  
Tel: +1 281 940 1800  
Fax: +1 713 559 9419  
info@amotusa.com

Roda Deaco by AMOT - Canada  
Tel: +1 780 465 4429  
Fax: +1 780 469 6275  
info@rodadeaco.com

### **Asia Pacific**

---

AMOT - China  
Tel: +86 (0)21 6279 7700  
Fax: +86 (0)21 5237 8560  
shanghai@amot.com

AMOT - Singapore  
Tel: +65 6408 6265  
Fax: +65 6408 6266  
singapore@amot.com

### **Europe, Middle East and Africa**

---

AMOT - UK  
Tel: +44 (0)1284 715739  
Fax: +44 (0)1284 715747  
info@amot.com

AMOT - Germany  
Tel: +49 (0)40 8537 1298  
Fax: +49 (0)40 8537 1331  
germany@amot.com

DS-HVX-300-500-ShutdownValves-CE2229-0712-rev1



Chalwyn's Quality Management System is approved by LRQA.

[www.chalwyn.com](http://www.chalwyn.com)

**CHALWYN**  
by AMOT