



# **D-Series Engine Overspeed Shut Down Valves**

**(Auto/Manual Bendix Types)**

## **Selection, Application and Maintenance**

**Valve Numbers**

D45-AM    D51-AM    D57-AM

D64-AM    D70-AM    D80-AM

## DESCRIPTION

A range of spring loaded poppet valves designed to automatically stop an engine by closing down the air intake should excessive overspeeding occur. Fitted with manual stop pull cable.

the closing force on the valve is provided by the intake air flow passing through. As the air flow increases, the closing force builds up. this is resisted by the valve spring force, the pre-load of which is adjustable such that at a given air flow the resulting force overcomes the spring resistance and causes the valve to close. once closed the valve will not reset to the open condition until the engine stops.

this type of valve may be fitted to either naturally aspirated or turbocharged engines. it should be noted however that for a given valve setting the repeatability of the actual automatic shut down speed has a greater scatter in the case of a turbocharged engine. however, unless for special reasons a precisely repeatable shut down speed is required, adequate protection from excessive overspeed and potential resulting damage is still achieved.

the basic dimensions for this family of valves are tabulated below

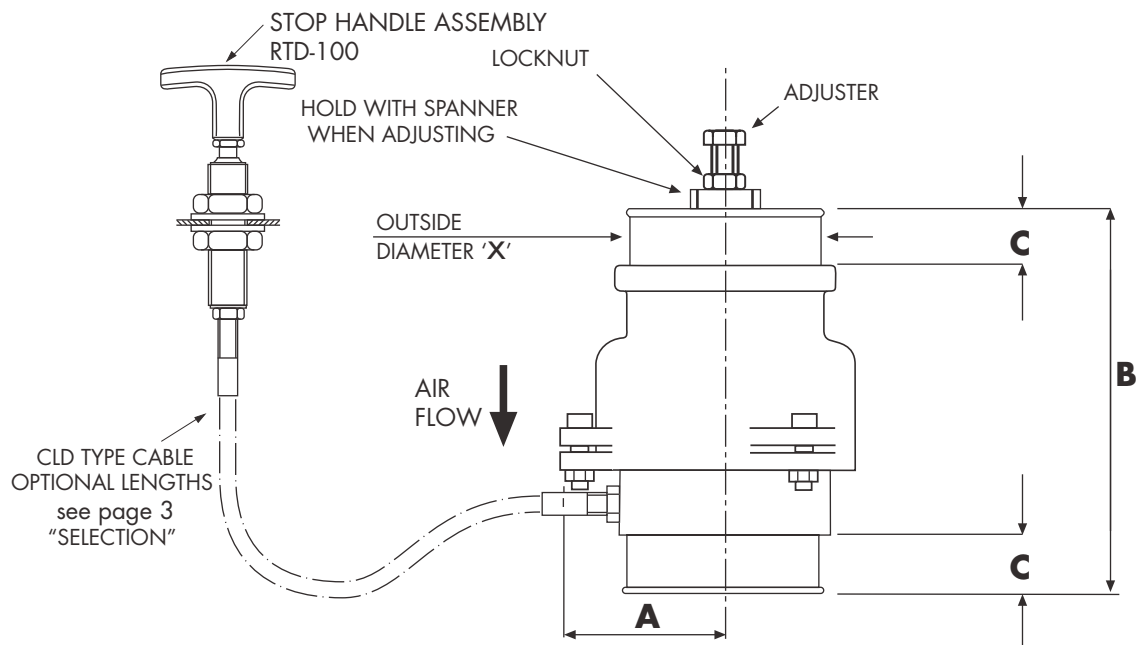

Valve Type	A mm	B mm	C mm	WEIGHT (valve only) Kg
D45-AM	54.0	125	19	0.75
D51-AM	58.0	128	19	0.8
D57-AM	62.7	131	19	0.95
D64-AM	67.5	132	19	1.1
D70-AM	74.5	134	19*	1.2
D80-AM	87.5	139**	19*	1.6

out side diameter 'X' is selected to suit the size of the engine air intake hose - see page 3 'sEIECTioN'

Dimensions marked \* increase to 25mm for outside diameter 'X' values of 86mm or greater

Dimensions marked \*\* increase to 145mm for outside diameter 'X' values of 86mm or greater

### Notes:

\* For smaller valve sizes see Chalwyn "Mini range" valve data sheet CE 209

\* For larger valve sizes see "spindle" and "D200" valve data sheets CE210 and CE 231

\* For integral air cleaner options see CE206

## SELECTION

Determine the rating of the engine to which the valve is to be fitted and whether or not turbocharged. using the table below identify which valve(s) would be suitable. Finalise the selection by identifying the valve which can also be supplied with end diameters "X" to match the bore of the engine air intake hose at the position the valve is to be fitted. Note, end diameters are manufactured to the nearest 1mm. generally, where more than one valve meets all requirements, select the larger valve size to minimise engine air intake restriction.

### Valve Selection chart in Metric Units

Valve Type	Engine power at rated speed kw		Engine Air intake hose Bore mm	
	Naturally Aspirated Engine	t urbocharged Engine	Minimum	Maximum
<b>D45-AM</b>	7.5 to 38	7.5 to 32	40	70
<b>D51-AM</b>	15 to 54	15 to 45	51	80
<b>D57-AM</b>	22 to 72	22 to 60	57	83
<b>D64-AM</b>	30 to 93	30 to 78	63	96
<b>D70-AM</b>	40 to 120	40 to 100	70	102
<b>D80-AM</b>	50 to 179	50 to 149	70	108

### Valve Selection chart in Non-metric Units

Valve Type	Engine power at rated speed hp		Engine Air intake hose Bore inches	
	Naturally Aspirated Engine	t urbocharged Engine	Minimum	Maximum
<b>D45-AM</b>	10 to 50	10 to 42	1 <sup>9</sup> / <sub>16</sub>	2 <sup>3</sup> / <sub>4</sub>
<b>D51-AM</b>	20 to 72	20 to 60	2	3 <sup>1</sup> / <sub>8</sub>
<b>D57-AM</b>	30 to 97	30 to 80	2 <sup>1</sup> / <sub>4</sub>	3 <sup>1</sup> / <sub>4</sub>
<b>D64-AM</b>	40 to 125	40 to 104	2 <sup>1</sup> / <sub>2</sub>	3 <sup>3</sup> / <sub>4</sub>
<b>D70-AM</b>	54 to 161	54 to 134	2 <sup>3</sup> / <sub>4</sub>	4
<b>D80-AM</b>	67 to 240	67 to 200	2 <sup>3</sup> / <sub>4</sub>	4 <sup>1</sup> / <sub>4</sub>

select the required length of the manual shut down cable from the table. Alternative lengths may be available on request.

### Selection Chart - Cable

CABLE PART N°	LENGTH (metres)
<b>CLD-100</b>	1.0
<b>CLD-150</b>	1.5
<b>CLD-200</b>	2.0
<b>CLD-300</b>	3.0



6. Particular care must be taken to ensure the integrity of the intake pipework between the Chalwyn valve and intake manifold. Ideally metal pipework should be used and any gaps kept as short as possible, (taking into account any relative movement) and closed by re-inforced hose. The possibility of a hose collapse on closure of the shut down valve should be avoided.
7. Any engine crankcase breather connections into the intake system between the Chalwyn valve and engine, or any internal crankcase breather arrangement venting directly into the engine intake ports, must be sealed and replaced by an external breather system venting either to atmosphere or to the intake system upstream of the shut down valve. External breather system kits for various engine types are available from Chalwyn.
8. Fit the 'T' handle assembly r t D-100 through a suitable  $\text{Ø}20\text{mm}$  ( $3/4\text{''}$  dia) hole in a bulkhead or mounting bracket as follows. Release the handle locknut. Remove the handle, handle locknut and upper locknut and washer. Thread handle body through the bulkhead/bracket. Refit upper locknut and washer. Adjust lower and upper locknuts to position handle and tighten. Refit handle locknut and handle. Tighten locknut.

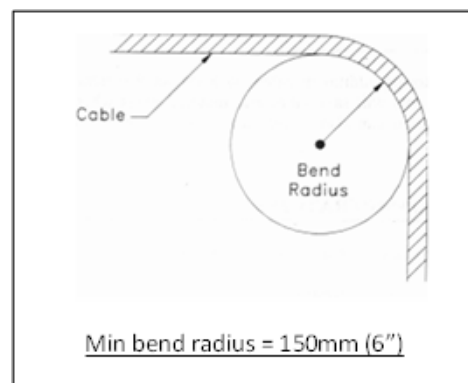
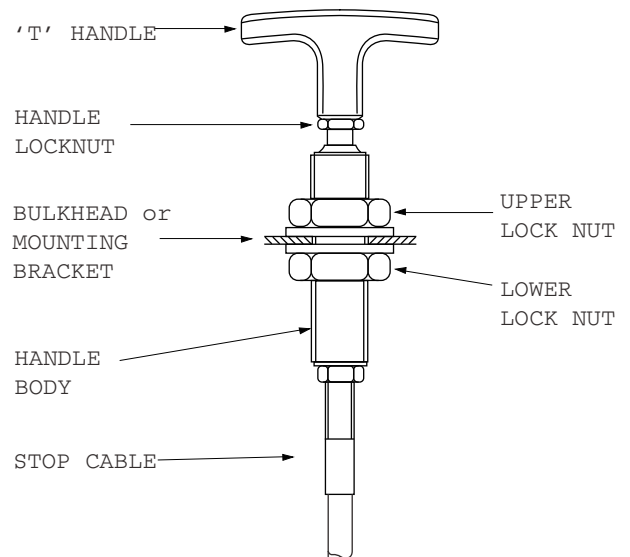

**Important Note.**

The Chalwyn valve manual shut down control is intended for emergency use and for system checking only. Always retain the engine fuel stop system for routine engine shut down.

## ADJUSTMENT

### SAFETY

#### WARNING

- When adjusting the D Valve, take care to ensure that contact with hot surfaces or entanglement in adjacent equipment is avoided

#### NOTE

- If a manual shut down cable assembly is fitted, ensure that excessive effort is not required to operate the manual override.

Once the Chalwyn valve is installed, adjustment of the overspeed trip setting is carried out using the adjuster and locknut (refer to diagrams). Basically rotating the adjuster clockwise will increase the engine speed at which automatic shut down occurs.

As supplied, the valve will be adjusted such that shut down will generally occur well below the engine high idle speed. to increase the speed at which automatic shut down occurs, proceed as follows:

1. Check that the manual shut down cable is in the run condition i.e. the 't' handle is pushed inward.
2. start engine. slowly accelerate. Note speed at which shut down occurs.
3. remove hose at **air inlet** to Chalwyn valve to expose the adjuster and locknut (see diagram).
4. release locknut. turn adjuster clockwise one turn. tighten locknut.
5. refit inlet hose to valve.
6. start engine. slowly accelerate. Note speed at which shut down occurs
7. repeat steps '3' to '6' until the first setting at which the engine does not shut down at high idle speed (i.e. full throttle, no load). then either:
  - a) *Use the results of shut down speed versus adjuster setting as a calibration check to make a final adjustment to give the required setting (typically 10% to 15% over high idle).*
  - or**
  - b) *If a very precise setting is not required, turn the adjuster a further one turn clockwise to take the shut down above high idle speed by a suitable margin. When using this setting procedure it may be found that the engine occasionally shuts down during the normal operation. If so, turn the adjuster clockwise by a further one half turn.*
8. Ensure the adjuster locknut is fully tightened. (use a thread lock adhesive on the locknut threads).

**Notes:**

**Turbocharged Engines**

when setting a valve fitted to a turbocharged engine using the preceding method, it may be found that at high engine power outputs, the engine will shut down at a lower speed than required. if this occurs, further small adjustments in steps of one half turn clockwise should be made until the problem is eliminated.

**Jammed Valve**

if in the course of adjusting a Bendix type valve it jams on its seat, release by turning **CLOCKWISE** viewed from adjuster end.

**MAINTENANCE**

**SAFETY**

**WARNING**

- When externally cleaning the valve ensure the engine is sufficiently cooled before commencing work, if cleaning a hot valve take extra care to avoid touching hot surfaces and to avoid entanglement in adjacent equipment.
- Take care not to trap fingers when making adjustments to the valve setting.
- Equipment contains springs, during dismantling ensure that spring forces are safely removed.
- When internally cleaning components with chemical agents avoid contact with skin, inhalation and ingestion of the cleaning agents and dirt / debris removed. Appropriate PPE should be worn.

**NOTES**

- No special handling requirements apply to the D Valve.
- Carefully read and fully understand the maintenance instructions before commencing work.
- Only competent personnel should maintain the D valve.
- Wear appropriate Personal Protective Equipment including safety footwear, safety glasses, thermal and oil resistant gloves and ear plugs.

Routine maintenance should be undertaken as below:

**Daily:** Run engine at a mid range speed. Check satisfactory shut down occurs when the manual emergency stop lever is operated.

### Three Monthly:

1. Disconnect intake pipework and release the valve from any support brackets etc. to allow it to be removed.
2. inspect the valve internally for cleanliness. if necessary, clean in paraffin or white spirit taking normal precautions. Dry the valve thoroughly.
3. Check there is no excessive wear and that the valve moves smoothly over its complete operating stroke. **DO NOT LUBRICATE.**
4. refit valve. Check valve setting based on the "Adjustment" instructions given herein.
5. with the engine running at medium speed pull the manual stop handle. the engine should come to a complete stop within a few seconds.

**Integral Engine Air Cleaner** (where fitted) replace air cleaner element at the periods recommended by the engine manufacturer.  
(spare elements are available from Chalwyn.)

#### **Important Notes:**

the three monthly routine maintenance period requirement is dependent on the operating conditions to which the equipment is exposed and, by experience, may need to be varied.

Any maintenance problems not covered by the routine maintenance schedule should be discussed with your Chalwyn Distributor before any repair work is undertaken



**Chalwyn by AMOT**

sales@chalwyn.co.uk  
www.chalwyn.com

A division of roper industries limited

**UK**

western way  
Bury st Edmunds  
suffolk, ip33 3sZ  
tel: +44 (0)1284 715739  
Fax: +44 (0)1284 715747

**USA**

8824 Fallbrook Drive  
houston  
TX 77064  
tel: +1 (281) 940 1800  
Fax: +1 (281) 668 8802

---

Chalwyn's Quality Management  
System is approved by LRQA.

